

Dual Fuel Kit

Installation Instructions

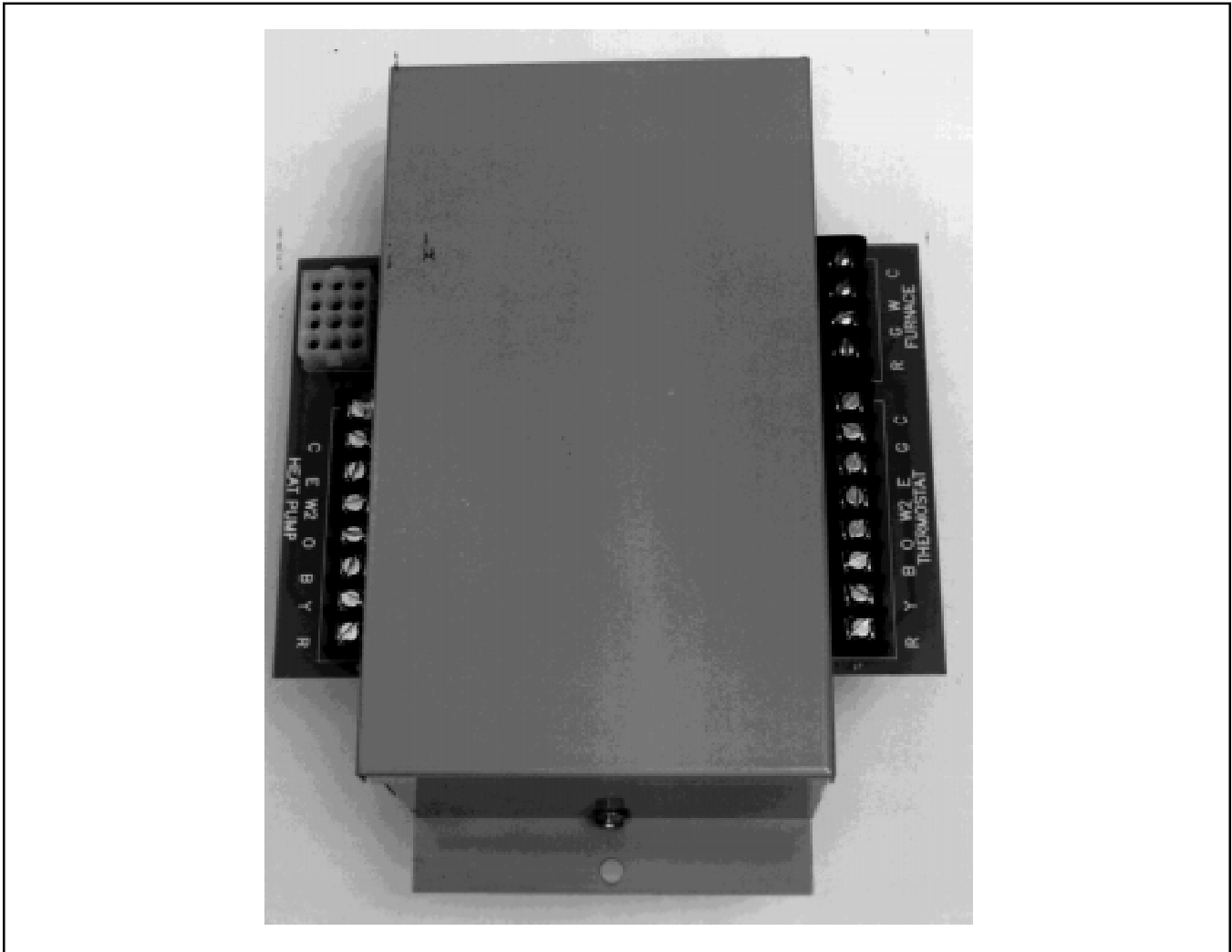

NOTE:

It is assumed that the Heat Pump and Furnace have already been installed. These instructions relate to the installation of the dual fuel kit only.

These instructions are primarily intended to assist qualified individuals experienced in the proper installation of this appliance. Some local codes require licensed installation/service personnel for this type of equipment. Read all instructions carefully before starting the installation.

! DANGER:

Ensure that all electrical power to the units are shut off prior to installing or servicing the equipment. Failure to do so may cause personal injury or death.

1. INSTALLATION

1. Mount the dual fuel kit in a convenient place close to the furnace.
2. Route the thermostat wires from the sub-base of the thermostat to the dual fuel kit thermostat connections.
3. Use thermostat wire or inter-connect cable to make the connections from the heat pump to the dual fuel kit connections marked "Heat Pump."

- Route the wires from "R, G, W, and C" mounted in the furnace or on the furnace relay kit, to the dual fuel kit furnace connections.

! WARNING:
Heat pump coils must be installed in the discharge air stream of the furnace. Use of a heat pump coil in the return air stream of a dual fuel furnace may cause excessive heat exchanger rusting and result in burner malfunction, fire hazard, and danger of asphyxiation.

- Proper operation of the dual fuel kit depends on having a single pole, close on temperature drop, thermostat in or near the outdoor heat pump unit, and connected between terminals "R" and "E." Figure 1 represents the overall system wiring diagram. Most Heat Pumps contain an appropriate outdoor thermostat, but it must be re-connected between terminals "R" and "E." Outdoor thermostat Part No. 913852 may be ordered for use with other heat pumps.

For Canadian Installations: Heat Pumps must use a High Pressure Cut-out to meet Canadian standards.

2. START-UP AND CHECK-OUT

! WARNING:
Ensure that electrical power to the unit is off prior to performing the following steps. Failure to do so may cause personal injury or death.

Prior to turning on any electrical power re-check that all power wiring connections are correct and tight. Also, make sure the outdoor unit and furnace have been properly and securely grounded.

Set the room thermostat system mode switch to OFF and the fan switch to AUTO. Move the cooling temperature setpoint to its highest setting, and the heating temperature setpoint to its lowest setting.

Using caution apply power first to the furnace, and then to the outdoor unit.

INDOOR BLOWER - Leaving the system mode switch off, move the fan switch to ON and verify that the indoor blower operates. Re-set the fan switch to AUTO.

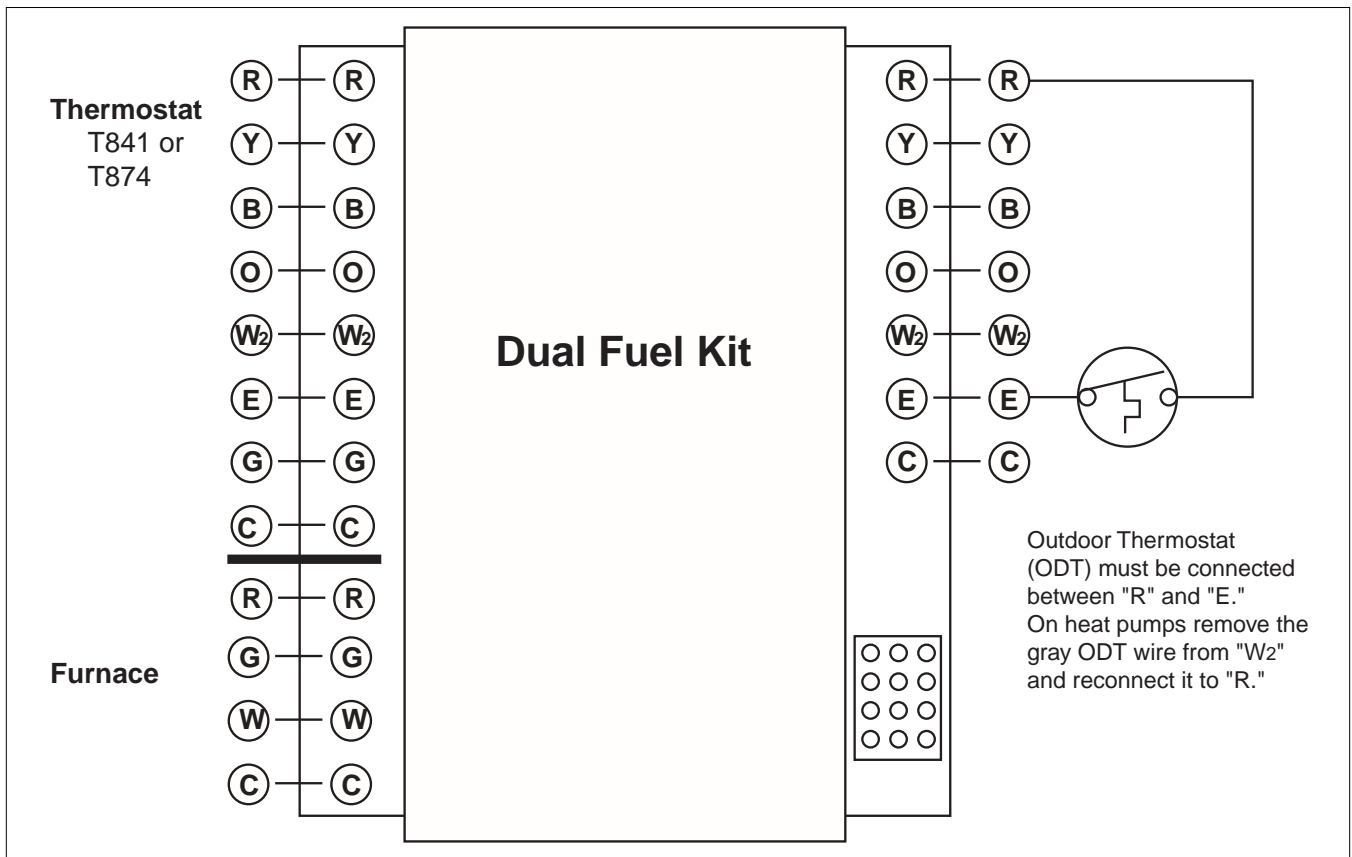

Figure 1. Dual Fuel Kit Terminal Location and System wiring Diagram

SPACE COOLING - Set the system mode switch to COOL or AUTO and gradually lower the thermostat cooling temperature setpoint. The reversing valve solenoid should energize when the manual change-over thermostat is set to COOL or when the first cooling bulb makes on the auto change-over thermostat. Continue lowering the thermostat cooling setpoint. The indoor blower and compressor should energize when the second cooling bulb makes.

Note that the system may have a built-in compressor short cycle protection. It insures that the compressor has a minimum off-time of five minutes after a run period or a power interruption. To bypass this protection for service purposes, the timer may be accelerated by jumpering the speed-up pins on the defrost board.

Stop the system by setting the thermostat system mode switch to OFF. The entire system will shut down, including de-energizing the reversing valve solenoid.

SPACE HEATING ABOVE THE ECONOMIC BALANCE POINT - With the outdoor thermostat set above the actual outdoor temperature or disconnected, move the cooling temperature setpoint to its highest setting, and the heating temperature setpoint to its lowest setting, then set the system mode switch to HEAT or AUTO.

Gradually increase the room thermostat heating setpoint until the first stage heating bulb energizes. The compressor, outdoor fan, and the indoor blower will energize.

Continue increasing the room temperature thermostat heating setpoint so that the second stage heating bulb energizes. The compressor and outdoor fan will stop, the indoor blower will continue to operate, and the furnace will begin its ignition sequence.

Gradually decrease the room thermostat heating setpoint so that the second stage heating bulb de-energizes. The furnace and indoor blower will continue to operate.

Continue decreasing the room thermostat heating setpoint so that the first stage heating bulb de-energizes. The furnace will stop heating, but the indoor blower will continue to operate until its bonnet fan switch opens, or the blower-off timer times out. The indoor blower will, however, change to heating speed if set different from cooling speed.

SPACE HEATING BELOW THE ECONOMIC BALANCE POINT - With the outdoor thermostat set at or below the actual outdoor temperature, or shorted, gradually increase the heating temperature setpoint until the first stage heating

bulb energizes. The furnace will begin its ignition sequence, with the indoor blower (and outdoor unit) remaining off. The indoor blower will start after its bonnet fan switch closes, or the blower-on timer times out.

Continue increasing the room thermostat heating setpoint until the second stage heating bulb energizes. There will be no change in the system operation.

Decrease the room thermostat heating setpoint until both the second stage and then the first stage heating bulbs de-energize. As the first stage heating bulb de-energizes, the furnace will stop heating, but the indoor blower will continue to operate until the bonnet fan switch opens, or the blower-off timer times out.

Make sure the outdoor thermostat is connected properly, and re-set it to the proper economic balance point.

3. CALCULATION OF THE ECONOMIC BALANCE POINT TEMPERATURE

DEFINITION:
ECONOMIC BALANCE POINT TEMPERATURE - This is the winter outdoor temperature at which the cost of operating the heat pump is equal to the cost of heating with gas or oil. Above the balance point, the heat pump will be less expensive to operate than the gas or oil furnace.

The following procedure will provide the most efficient use of the two heating sources.

1. In Table 1, move down the heat pump electric rate column to the electric rate for your area. Then follow that row to the right to either the 10 or 12 SEER column to match your heat pump efficiency. The result letter represent your heat pump's cost of operation curve presented in Figure 2.

Example: An electric rate of .07 \$/Kwh with a 10 SEER heat pump will use curve "E."

2. Next, select your furnace type in Table 1, and move down its fuel cost column to the fuel rate for your area. Then follow that row to the right to either the 70%, 80%, or 90% AFUE column, to match your furnace efficiency. The resulting number represents your furnace's cost of operation curve presented in Figure 2.

Example: A gas rate of \$.70 /CCF with an 80% AFUE furnace will use curve "8."

3. Still using Figure 2, find the intersection of the two curves identified in the examples above were "E" and "8." Dropping down to the outdoor temperature scale from the intersection of curve "E" and "8," yields a temperature (economic balance point) of 30°F.

4. Adjust the outdoor thermostat to your economic balance point temperature.

ELECTRIC RATE \$/KWH	HEAT PUMP		GAS FURNACES			PROPANE FURNACES			OIL FURNACES				
	10 SEER CURVE	12 SEER CURVE	GAS COST \$/CCF	75% AFUE CURVE	80% AFUE CURVE	90% AFUE CURVE	PROPANE COST \$/GAL	75% AFUE CURVE	80% AFUE CURVE	90% AFUE CURVE	OIL COST \$/GAL	75% AFUE CURVE	80% AFUE CURVE
0.04	B	A	0.45	11	13	-	.60	6	8	-	.85	8	-
0.05	C	B	0.50	10	12	13	.65	5	7	-	0.90	7	-
0.06	D	C	0.55	9	11	12	.70	4	6	8	0.90	6	8
0.07	E	D	0.60	8	10	11	.75	3	5	7	1.00	5	7
0.08	F	E	0.65	7	9	10	.80	2	4	6	1.05	4	6
0.09	G	F	0.70	6	8	9	.85	1	3	5	1.10	3	5
0.10	-	G	0.75	-	7	8	.90	-	2	4	1.15	2	4
-	-	-	0.80	-	6	7	.95	-	1	3	1.20	1	3

Table 1

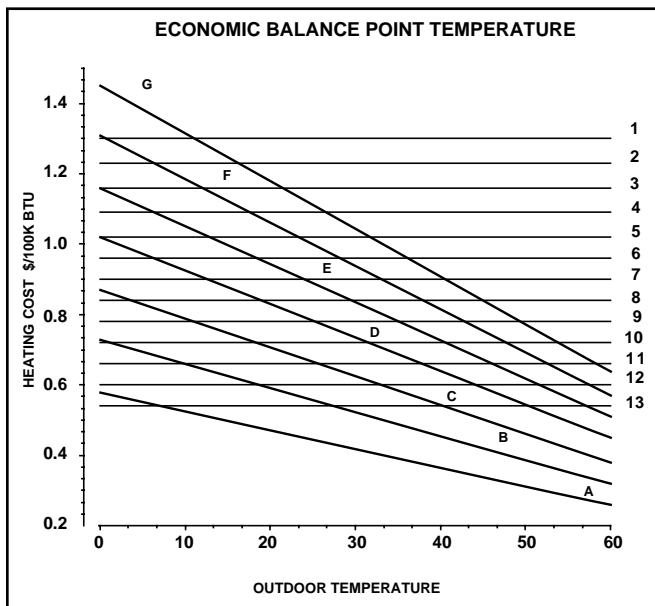

Figure 2. Economic Balance Point Temperature

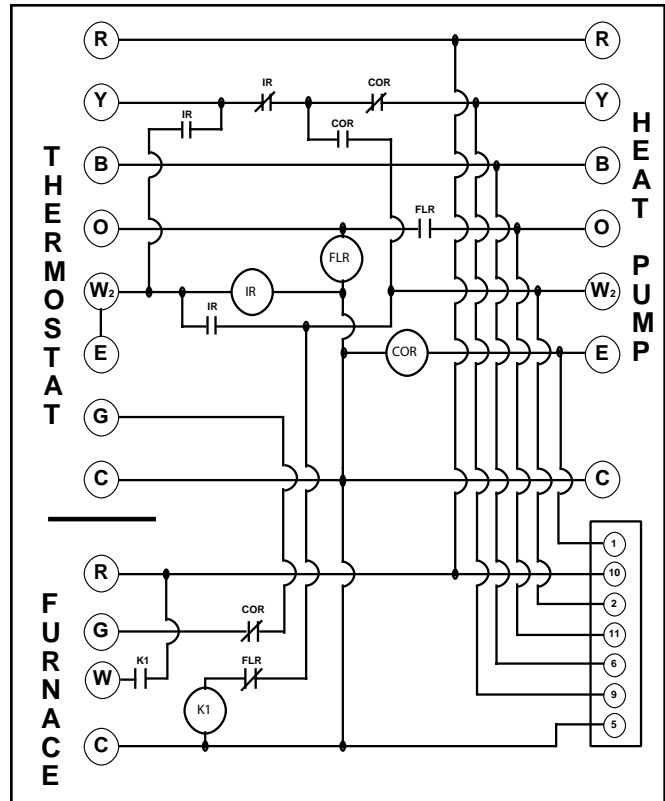

Figure 3. Dual Fuel Kit Electrical Schematic

INSTALLER: PLEASE LEAVE THESE INSTALLATION INSTRUCTIONS WITH THE HOMEOWNER

